

TALEXconverter LCAI 20W 350mA–550mA ECO Ip ECO series

Product description

- Dimmable built-in LED control gear for LED
- Constant current LED control gear
- Output current adjustable between 350 – 550 mA
- Max. output power 20 W
- Nominal life-time up to 100,000 h
- 5-year guarantee
- Dimming range 1 ... 100 %

Properties

- Low-profile metal casing with white cover
- Type of protection IP20

Interfaces

- DALI DEVICE Type 6
- DSI
- switchDIM (with memory function)
- corridorFUNCTION

Functions

- Adjustable output current (I-select resistor or DALI)
- Power-up fading at AC
- Intelligent Temperature Guard (overtemperature protection)
- Short-circuit proof
- Overload protection
- Constant Light Output function
- Suitable for emergency lighting units acc. to EN50172



Standards, page 4

IP20 SELV          RoHS

TALEXconverter LCAI 20W 350mA–550mA ECO Ip ECO series

Technical data

Rated supply voltage	220 – 240 V
Input voltage, AC	198 – 264 V
Input voltage, DC	170 – 280 V
Mains frequency	0 / 50 / 60 Hz
Typ. current (at 230 V, 50 Hz, full load) ^① ⊗	90 – 110 mA
Typ. current (220 V, 0 Hz, full load, 15 % dimming level) ^②	15 – 20 mA
Leakage current (PE)	< 0,5 mA
Max. input power	25 W
Typ. efficiency (at 230 V / 50 Hz / full load) ^③	85.3 – 86.7 %
λ (at 230 V, 50 Hz, full load) ^④	0.83 – 0.95
Typ. power input on standby ^⑤	120 – 140 mW
THD (at 230 V, 50 Hz, full load)	< 22 %
Time to light (at 230 V, 50 Hz, full load, acc. to DALI)	< 0.6 s
Time to light (DC mode)	< 0.4 s
Switchover time (AC/DC)	< 0.4 s
Turn off time (at 230 V, 50 Hz, full load)	< 50 ms
Hold on time (at 230 V, 50 Hz, full load) ^⑥	15 ms
Output current tolerance ^⑦	± 3 %
Output current ripple	± 15 %
Max. repetitive output peak current	≤ Ausgangsstrom + 18 %
Max. non-repetitive output peak current	≤ Ausgangsstrom + 18 %
PWM frequency ^⑧	500 Hz
Dimming range	1 – 100 %
Max. output voltage	60 V
Dimensions L x W x H	280 x 30 x 21 mm

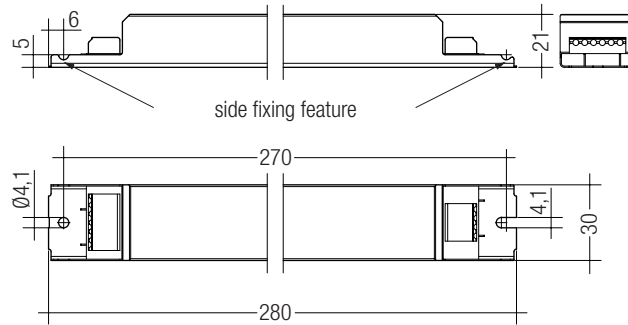

Ordering data

Type	Article number	Packaging carton	Packaging pallet	Weight per pc.
LCAI 20W 350mA-550mA ECO Ip	28000841	10 pc(s).	960 pc(s).	0.193 kg

Specific technical data

Type	Output current	Min. forward voltage	Max. forward voltage ^①	Max. output power ^②	Typ. power consumption (at 230 V, 50 Hz, full load)	Typ. current consumption (at 230 V, 50 Hz, full load)	Max. casing temperature t _c	Ambient temperature t _a max.	I-select resistor value
LCAI 20W 350mA-550mA ECO Ip	350 mA	23 V	50 V	17.5 W	19.7 W	91 mA	80 °C	-25 ... +65 °C	open
	375 mA	23 V	50 V	19.0 W	21.2 W	97 mA	80 °C	-25 ... +65 °C	71.50 kΩ
	400 mA	23 V	50 V	20.0 W	22.7 W	103 mA	80 °C	-25 ... +65 °C	66.50 kΩ
	425 mA	21 V	47 V	20.0 W	22.7 W	103 mA	80 °C	-25 ... +65 °C	61.90 kΩ
	450 mA	20 V	44 V	20.0 W	22.1 W	105 mA	80 °C	-25 ... +65 °C	57.60 kΩ
	475 mA	19 V	42 V	20.0 W	23.1 W	105 mA	80 °C	-25 ... +65 °C	53.60 kΩ
	500 mA	18 V	40 V	20.0 W	23.2 W	105 mA	80 °C	-25 ... +65 °C	49.90 kΩ
	525 mA	17 V	38 V	20.0 W	23.0 W	105 mA	80 °C	-25 ... +65 °C	45.30 kΩ
	550 mA	16 V	36 V	20.0 W	23.1 W	105 mA	80 °C	-25 ... +65 °C	short circuit (0 Ω)

^① Valid at 100 % dimming level.

^② Depending on the selected output current.

^③ Depending on the DALI traffic at the interface.

^④ At power failure.

^⑤ ± 20 %.

^⑥ At full load.

Product description

- Ready-for-use resistor to set output current value
- Resistor is base isolated
- Resistor power 0.25 W
- Resistor value tolerance $\pm 1\%$

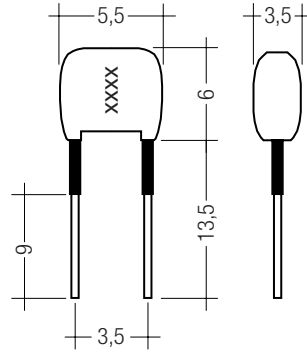

Ordering data

Type	Article number	Colour	Marking	Resistor value	Packaging bag	Weight per pc.
I-SELECT PLUG MAX GR	28000274	Grey	MAX	0.0 Ω	10 pc(s).	0.001 kg
I-SELECT PLUG 500mA GN	28000277	Green	0500	49.9 k Ω	10 pc(s).	0,001 kg

1. Standards

EN 55015
EN 61000-3-2
EN 61000-3-3
EN 61347-1
EN 61347-2-13
EN 62384
EN 61547
EN 62386-101 (according to DALI standard V1)
EN 62386-102
EN 62386-207
According to EN 50172 for use in central battery systems
According to EN 60598-2-22 suitable for emergency lighting installations

1.1 Isolation and electric strength testing of luminaires

Electronic devices can be damaged by high voltage. This has to be considered during the routine testing of the luminaires in production.

According to IEC 60598-1 Annex Q (informative only!) or ENEC 303-Annex A, each luminaire should be submitted to an isolation test with 500 V_{DC} for 1 second. This test voltage should be connected between the interconnected phase and neutral terminals and the earth terminal.

The isolation resistance must be at least 2 MΩ.

As an alternative, IEC 60598-1 Annex Q describes a test of the electrical strength with 1500 V_{AC} (or 1.414 x 1500 V_{DC}). To avoid damage to the electronic devices this test must not be conducted.

2. Thermal details

2.1 Conditions of use and storage

Humidity: 5% up to max. 85%,
not condensed
(max. 56 days/year at 85%)

Storage temperature: -40 °C up to max. +80 °C

The devices have to be within the specified temperature range (ta) before they can be operated.

2.2 Overtemperature protection

The LED control gear is protected against temporary thermal overheating. If the temperature limit is exceeded the output current of the LED is reduced. The temperature protection is activated approx. +5 °C above t_c max (see page 2). On DC operation this function is deactivated to fulfill emergency requirements.

3. Installation / wiring

3.1 Hot plug-in

Hot plug-in is not recommend within 5 s after shutdown due to output voltage of > 0 V. If a LED load is connected the device has to be restarted before the output will be activated again.

This can be done with mains reset, DALI, DSI or switchDIM.

3.2 Circuit diagram

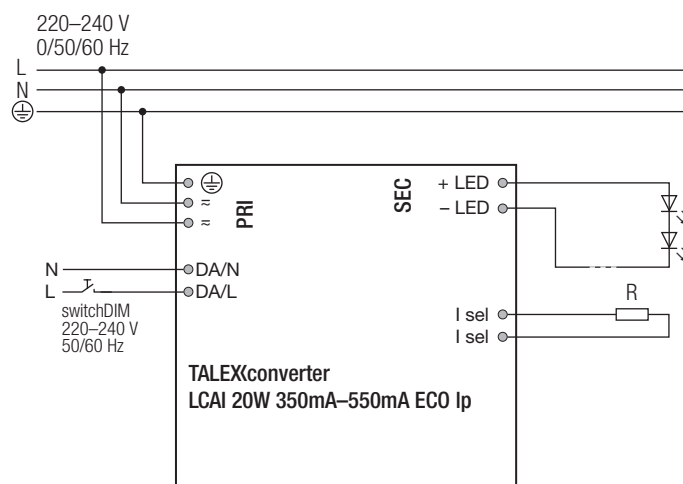
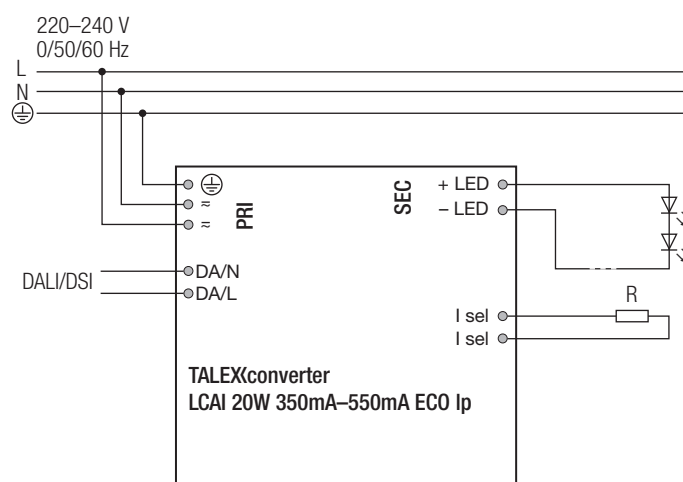

3.3 Wiring type and cross section

Solid wire with a cross section of 0.5 – 1.5 mm². Strip 8 – 9 mm of insulation from the cables to ensure perfect operation of terminals.

LED module/LED control gear/supply

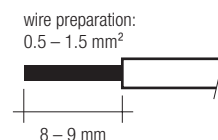

3.4 Loose wiring

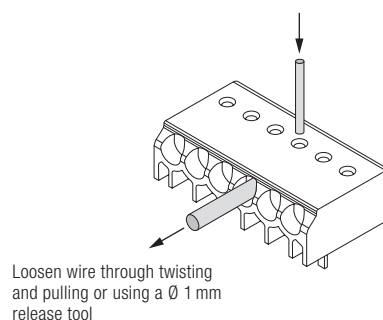

3.5 Wiring guidelines

- The cables should be run separately from the mains connections and mains cables to ensure good EMC conditions.
- The LED wiring should be kept as short as possible to ensure good EMC. The max. secondary cable length is 2 m (4 m circuit), this applies for LED output as well as for I-select.
- Secondary switching is not permitted.
- The LED control gear has no inverse-polarity protection on the secondary side. Wrong polarity can damage LED modules with no inverse-polarity protection.

3.6 Installation note

Max. torque at the clamping screw: 0.5 Nm / M4

3.7 Additional information

Additional technical information at
www.tridonic.com → Technical Data

Guarantee conditions at
www.tridonic.com → Services

No warranty if device was opened.

4. Life-time

4.1 Expected life-time

Type	Output current	ta	50 °C	55 °C	60 °C	65 °C
LCAI 20W 350mA-550mA ECO Ip	350 mA	tc	65 °C	70 °C	75 °C	80 °C
		Life-time	> 150,000 h	> 100,000 h	85,000 h	60,000 h
	375 – 550 mA	tc	65 °C	70 °C	75 °C	80 °C
		Life-time	> 150,000 h	> 100,000 h	85,000 h	60,000 h

5. Electrical values

5.1 Efficiency vs load

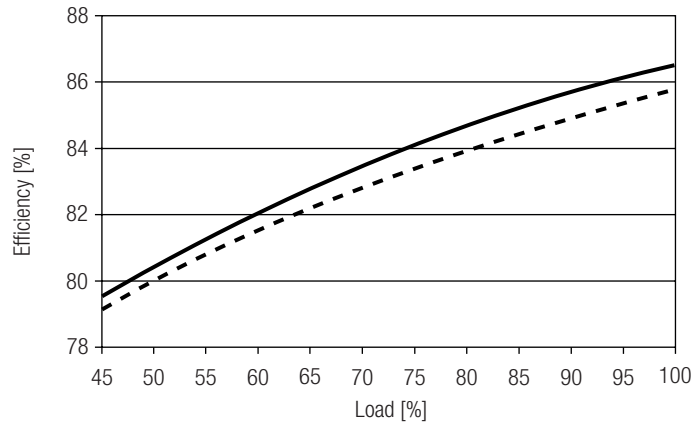

5.2 Power factor vs load

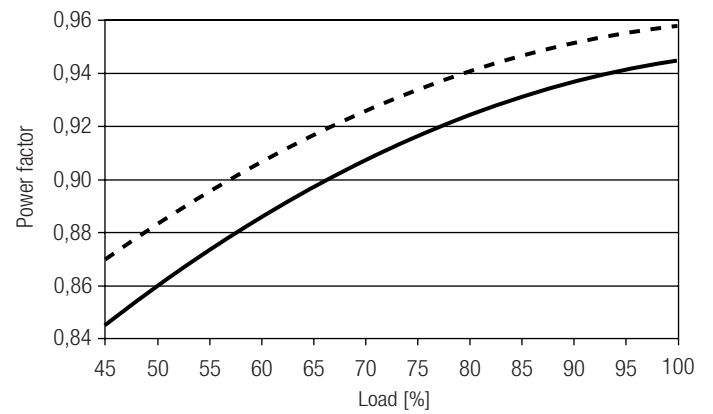

5.3 THD vs load

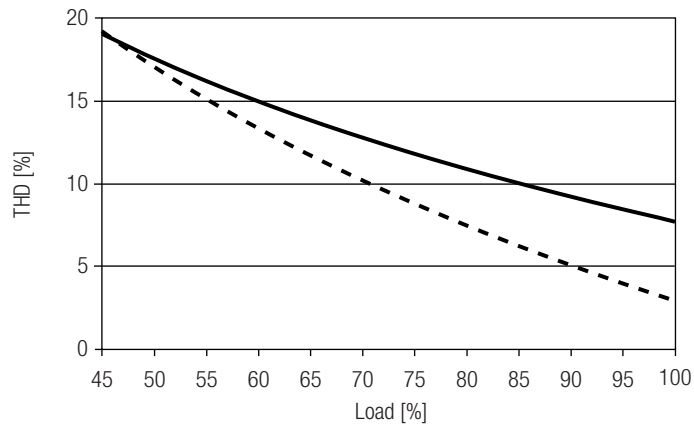

— 350 mA
- - - 550 mA

100 % load correspond to the max. output power (full load) according to the table on page 2.

5.4 Maximum loading of automatic circuit breakers

Automatic circuit breaker type	C10	C13	C16	C20	B10	B13	B16	B20	Inrush current	
	Installation Ø	1.5 mm ²	1.5 mm ²	2.5 mm ²	2.5 mm ²	1.5 mm ²	1.5 mm ²	2.5 mm ²	2.5 mm ²	I _{max}
LCAI 20W 350mA-550mA ECO Ip	60	80	100	140	60	80	100	140	6 A	45 µs

5.5 Digital signal DALI/DSI

The control input is non-polar for digital control signals (DALI, DSI). The control signal is not SELV. Control cable has to be installed in accordance to the requirements of low voltage installations. Different functions depending on each module.

5.6 Dimming

Dimming range 1 % to 100 %

Digital control with:

- DSI signal: 8 bit Manchester Code
Speed 1 % to 100 % in 1.4 s
- DALI signal: 16 bit Manchester Code
Speed 1 % to 100 % in 0.2 s
Programmable parameter:
Minimum dimming level
Maximum dimming level
Default minimum = 1 %
Programmable range $1\% \leq \text{MIN} \leq 100\%$
Default maximum = 100 %
Programmable range $100\% \geq \text{MAX} \geq 1\%$

Dimming curve is adapted to the eye sensitiveness.

Dimming is realized by a combination of analog amplitude dimming and PWM dimming.

35 ... 100 %: amplitude dimming

1 ... 34 %: PWM dimming

5.7 Dimming characteristics

Digital dimming value

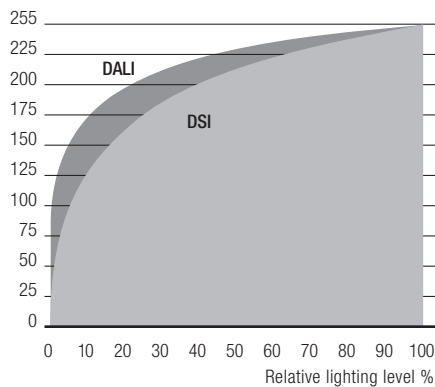

Dimming characteristics as seen by the human eye

5.8 Harmonic distortion in the mains supply (at 230 V / 50 Hz and full load) in %

	THD	3.	5.	7.	9.	11.
LCAL 20W 350mA-550mA ECO Ip	6	< 5	< 6	< 4	< 3	< 3

6. Interfaces / communication

6.1 Control input (DA/N, DA/L)

Digital DALI signal or switchDIM can be wired on the same terminals (DA/N and DA/L).

6.2 switchDIM

Integrated switchDIM function allows a direct connection of a push to make switch for dimming and switching.

Brief push (< 0.6 s) switches LED control gear ON and OFF. The LED control gears switch-ON at light level set at switch-OFF.

When the push to make switch is held, LED modules are dimmed. After repush the LED modules are dimmed in the opposite direction.

In installations with LED control gears with different dimming levels or opposite dimming directions (e.g. after a system extension), all LED control gears can be synchronized to 50 % dimming level by a 10 s push.

Use of push to make switch with indicator lamp is not permitted.

7. Functions

7.1 Short-circuit behaviour

In case of a short circuit at the LED output the LED output is switched off. After restart of the LED control gear the output will be activated again. The restart can either be done via mains reset or via interface (DALI, DSI, switchDIM).

7.2 No-load operation

The LED control gear will not be damaged in the no-load operation. The output will be deactivated and therefore free of voltage. If a LED load is connected the device has to be restarted before the output will be activated again.

7.3 corridorFUNCTION

The corridorFUNCTION can be programmed in two different ways.

To program the corridorFUNCTION by means of software a DALI-USB interface is needed in combination with a DALI PS. The software can be the masterCONFIGURATOR.

To activate the corridorFUNCTION without using software a voltage of 230 V simply has to be applied for five minutes at the switchDIM connection. The unit will then switch automatically to the corridorFUNCTION.

Note:

If the corridorFUNCTION is wrongly activated in a switchDIM system (for example a switch is used instead of pushbutton), there is the option of installing a pushbutton and deactivating the corridorFUNCTION mode by five short pushes of the button within three seconds.

switchDIM and corridorFUNCTION are very simple tools for controlling ballasts with conventional momentary-action switches or motion sensors.

To ensure correct operation a sinusoidal mains voltage with a frequency of 50 Hz or 60 Hz is required at the control input.

Special attention must be paid to achieving clear zero crossings. Serious mains faults may impair the operation of switchDIM and corridorFUNCTION.

7.4 Overload protection

If the output voltage range is exceeded the LED control gear turns off the LED output. After restart of the LED control gear the output will be activated again. The restart can either be done via mains reset or via interface (DALI, DSI, switchDIM).

7.5 Function of the earth terminal

The device does not need to be earthed for safety reasons. An earth connection may however improve the following unwanted behaviour:

- poor interference properties
- residual LED glow on standby
- transfer of mains transients to the LED output

For modules that are installed on earthed luminaire components or on heat sinks and which therefore have a high capacitance with regard to earth it is generally recommended that the device be also earthed. If an earth connection is used it must be a protective earth (PE).

7.6 Function: adjustable current (I-select)

The output current of the LED control gear can be selected between 350 and 550 mA. For adjustment there are two options available.

Option 1: „I-select resistor“

In 25 mA steps adjustable (see page 2, specific technical data, „I-select resistor value“).

Relationship between output current and resistor value can be found at the table “Specific technical data”. Resistor values specified from standardised resistor value ranges. Resistor value tolerance has to be $\leq 1\%$. Resistor power has to be $\geq 0.1\text{ W}$. If the resistor is connected with wires a max. wire length of 2 m may not be exceeded and possible interferences have to be avoided.

Resistors for the main output current values can be ordered from Tridonic (see accessories).

Option 2: DALI

Adjustment is done by masterCONFIGURATOR (see masterCONFIGURATOR documentation).

7.7 Light level in DC operation

Programmable from 1 – 100 %

Programming by extended DSI or DALI signal (16 bit).

Default value is 15 %

In DC operation dimming mode can be activated.

7.8 Power-up fading

The power-up fading function offers the opportunity to realise a soft start. The soft start will be applied at turning on the mains and at starts by switchDIM. The function is programmed as a DALI fade time in the range from 0.7 to 16 seconds and dims in the selected time from 0 % to the power-on level. By factory default power-up fading is not active (0 seconds).

7.9 Constant light output (CLO)

The luminous flux of an LED decreases constantly over the life-time. The CLO function ensures that the emitted luminous flux remains stable. For that purpose the LED current will increase continuously over the LED life-time. In masterCONFIGURATOR it is possible to select a start value (in percent) and an expected life-time. The LED control gear adjusts the current afterwards automatically.

7.10 Software / programming

With appropriate software and a USB interface different functions can be activated and various parameters can be configured in the LED control gear. All that is needed is a DALI-USB and the software (masterCONFIGURATOR).

7.11 masterCONFIGURATOR

From version 2.8:

For programming functions (CLO, I-select, power-up fading, corridorFUNCTION) and device settings (fade time, ePowerOnLevel, DC level, etc.). For further information see masterCONFIGURATOR manual.