



TALEXmodule LLE G3 16x140mm 325lm ADV, LLE G3 16x280mm 650lm

ADV

TALEXmodule LLE

Product description

- Ideal for compact linear luminaires designs
- Homogenous illumination thanks to small package distance
- Best refurbishment option for T5 lamps
- Luminous flux range 290 up to 850 lm
- LED system solution with outstanding system efficacy up to 140 lm/W, consisting of linear LED modules and LED control gear LCI 65W 150–400mA TOP Ip
- Efficacy of the module up to 150 lm/W
- High colour rendering index CRI > 80
- Small colour tolerance MacAdam 3[®]
- Small luminous flux tolerances
- Colour temperatures 3,000 K and 4,000 K
- Perfectly uniform light, even if several LED modules are used together in a line
- Push terminals for quick and simple wiring of LED module to LED module
- Simple installation (push-fix bridge or screws)
- Long life-time: 50,000 hours
- 5-year guarantee



Standards, page 5

Colour temperatures and tolerances, page 9



TALEXmodule LLE G3 16x140mm 325lm ADV, LLE G3 16x280mm 650lm ADV

TALEXmodule LLE

Technical data

Beam characteristic	120°
Ambient temperature t_a	-25 ... +45 °C
Typ. tp point	65 °C
Risk group (EN 62471:2008)	1
ESD classification	severity level 4
Type of protection	IP00

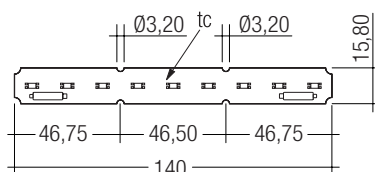
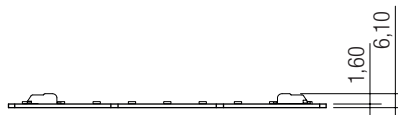

LLE G3 16x140mm 325lm ADV

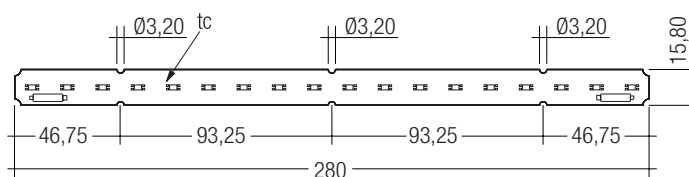
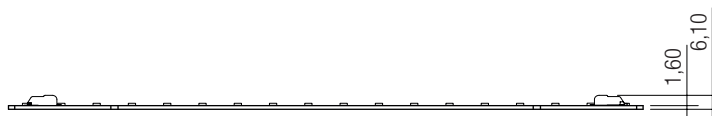

LLE G3 16x280mm 650lm ADV

Ordering data

Type	Article number	Colour temperature	Packaging carton	Weight per pc.
LLE G3 16x140mm 325lm 830 ADV	89602054	3.000 K	1,440 pc(s).	0.008 kg
LLE G3 16x140mm 325lm 840 ADV	89602055	4.000 K	1,440 pc(s).	0.008 kg
LLE G3 16x280mm 650lm 830 ADV	89602058	3.000 K	600 pc(s).	0.016 kg
LLE G3 16x280mm 650lm 840 ADV	89602059	4.000 K	600 pc(s).	0.016 kg

Specific technical data

Type [®]	Photo-metric code	Typ. luminous flux at tp = 25 °C ^①	Typ. luminous flux at tp = 65 °C ^①	Typ. forward current ^{② ③ ④}	Min. forward voltage at tp = 65 °C	Max. forward voltage at tp = 25 °C	Typ. power consumption at tp = 65 °C ^⑤	Efficacy of the module at tp = 25 °C	Efficacy of the module at tp = 65 °C	Efficacy of the system at tp = 65 °C	Colour rendering index CRI	Energy classification
Operating mode HE at 250 mA												
LLE G3 16x140mm 325lm 830 ADV	830/349	315 lm	290 lm	250 mA	7.80 V	9.1 V	2.1 W	144 lm/W	138 lm/W	126 lm/W	> 80	A++
LLE G3 16x140mm 325lm 840 ADV	840/349	335 lm	315 lm	250 mA	7.80 V	9.1 V	2.1 W	154 lm/W	150 lm/W	137 lm/W	> 80	A++
LLE G3 16x280mm 650lm 830 ADV	830/349	625 lm	570 lm	250 mA	15.60 V	18.2 V	4.2 W	144 lm/W	136 lm/W	124 lm/W	> 80	A++
LLE G3 16x280mm 650lm 840 ADV	840/349	670 lm	630 lm	250 mA	15.60 V	18.2 V	4.2 W	154 lm/W	150 lm/W	137 lm/W	> 80	A++
Operating mode HO at 300 mA												
LLE G3 16x140mm 325lm 830 ADV	830/349	370 lm	340 lm	300 mA	8.00 V	9.3 V	2.5 W	140 lm/W	136 lm/W	124 lm/W	> 80	A++
LLE G3 16x140mm 325lm 840 ADV	840/349	400 lm	370 lm	300 mA	8.00 V	9.3 V	2.5 W	151 lm/W	148 lm/W	135 lm/W	> 80	A++
LLE G3 16x280mm 650lm 830 ADV	830/349	735 lm	675 lm	300 mA	16.00 V	18.6 V	5.1 W	139 lm/W	132 lm/W	120 lm/W	> 80	A++
LLE G3 16x280mm 650lm 840 ADV	840/349	795 lm	740 lm	300 mA	16.00 V	18.6 V	5.1 W	150 lm/W	145 lm/W	132 lm/W	> 80	A++
Operating mode HO at 350 mA												
LLE G3 16x140mm 325lm 830 ADV	830/349	425 lm	395 lm	350 mA	8.15 V	9.5 V	3.0 W	136 lm/W	132 lm/W	120 lm/W	> 80	A++
LLE G3 16x140mm 325lm 840 ADV	840/349	455 lm	430 lm	350 mA	8.15 V	9.5 V	3.0 W	145 lm/W	143 lm/W	130 lm/W	> 80	A++
LLE G3 16x280mm 650lm 830 ADV	830/349	840 lm	780 lm	350 mA	16.30 V	18.9 V	6.0 W	134 lm/W	130 lm/W	118 lm/W	> 80	A++
LLE G3 16x280mm 650lm 840 ADV	840/349	910 lm	850 lm	350 mA	16.30 V	18.9 V	6.0 W	146 lm/W	142 lm/W	129 lm/W	> 80	A++

^① Tolerance range for optical and electrical data: ±10 %.

^② Max. permissible repetitive peak current: 600 mA.

^③ Max. permissible surge current: 1.5 A, duration max. 10 µs.

^④ Integral measurement over the complete module.

^⑤ HE ... high efficiency, HO ... high output.

ACCESSORIES

BRIDGE LLE16

Product description

- Clip for fixation for LLE16
- Fast snap on mounting (for sheet thickness 0.5 – 1.0 mm)
- Clip made of polycarbonate

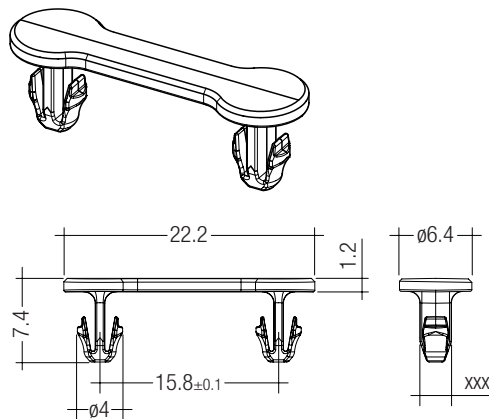

Ordering data

Type	Article number	Colour	Packaging carton	Weight per pc.
ACL BRIDGE LLE16 PUSH-FIX	28001035	White	tbd Stk.	0.0002 kg

Product description

- LINEAR COVER for LLE 16
- Protection against direct touch for non-SELV applications
- Fast snap on mounting on to LLE 16 with clips or plastic washers
- High transmission: transparent 94 %, semi-transparent 87 %, diffuse 76 %
- Linear lense made of PMMA
- Tolerances LINEAR COVER: + 20 mm for 1,600 mm length (ends raw)

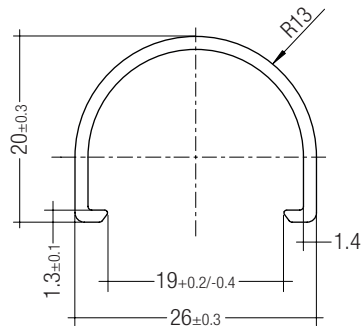
**Ordering data**

Type	Article number	Colour	Length	Packaging carton	Weight per pc.
ACL LINEAR COVER 16x1600mm TRANSPARENT	28000949	Transparent	1,600 mm	tbd pc(s).	0.147 kg
ACL LINEAR COVER 16x1600mm FROSTED	28000950	Semi-transparent	1,600 mm	tbd pc(s).	0.147 kg
ACL LINEAR COVER 16x1600mm DIFFUSE	28000951	Diffuse	1,600 mm	tbd pc(s).	0.147 kg

1. Standards

IEC 62031
IEC 62471
IEC 62717
IEC 61000-4-2

1.1 Photometric code

Key for photometric code, e. g. 830 / 349

1 st digit	2 nd + 3 rd digit	4 th digit	5 th digit	6 th digit	
Code	CRI	Colour temperature in Kelvin x 100	McAdams initial	McAdams after 25% of the life-time (max.6000h)	
				Code	Remaining lumen
7	67 – 76			7	≥ 70 %
8	77 – 86			8	≥ 80 %
9	87 – ≥90			9	≥ 90 %

2. Thermal details

2.1 tc point, ambient temperature and life-time

The temperature at tp reference point is crucial for the light output and life-time of a TALEX product.

For TALEXmodule LLE a tp temperature of 65 °C has to be complied in order to achieve an optimum between heat sink requirements, light output and life-time.

Compliance with the maximum permissible reference temperature at the tc point must be checked under operating conditions in a thermally stable state. The maximum value must be determined under worst-case conditions for the relevant application.

The tc and tp temperature of LED modules from Tridonic are measured at the same reference point.

2.2 Thermal behaviour

storage temperature	-30... +80 °C
operating temperature ta	-25... +45 °C
tp (at typ. current)	65 °C
tc max. (at typ. current)	85 °C
max. humidity	0... 70 %

* not condensating

2.3 Thermal design and heat sink

The rated life of TALEX products depends to a large extent on the temperature. If the permissible temperature limits are exceeded, the life of the TALEXmodule LLE will be greatly reduced or the TALEXmodule LLE may be destroyed.

2.4 Heat sink values

TALEXmodule LLE-G3-16-140

ta	tp	Forward current	R _{th, hs-a}	Cooling area
25 °C	65 °C	250 mA	34.8 K/W	19 cm ²
25 °C	65 °C	300 mA	27.8 K/W	24 cm ²
25 °C	65 °C	350 mA	23.3 K/W	29 cm ²
35 °C	65 °C	250 mA	25.4 K/W	26 cm ²
35 °C	65 °C	300 mA	20.8 K/W	32 cm ²
35 °C	65 °C	350 mA	17.6 K/W	47 cm ²
45 °C	65 °C	250 mA	16.9 K/W	40 cm ²
45 °C	65 °C	300 mA	13.8 K/W	48 cm ²
45 °C	65 °C	350 mA	11.7 K/W	71 cm ²

TALEXmodule LLE-G3-16-280

ta	tp	Forward current	R _{th, hs-a}	Cooling area
25 °C	65 °C	250 mA	17.3 K/W	38 cm ²
25 °C	65 °C	300 mA	13.9 K/W	48 cm ²
25 °C	65 °C	350 mA	11.7 K/W	57 cm ²
35 °C	65 °C	250 mA	12.7 K/W	52 cm ²
35 °C	65 °C	300 mA	10.4 K/W	64 cm ²
35 °C	65 °C	350 mA	8.8 K/W	76 cm ²
45 °C	65 °C	250 mA	8.4 K/W	79 cm ²
45 °C	65 °C	300 mA	6.9 K/W	96 cm ²
45 °C	65 °C	350 mA	5.8 K/W	114 cm ²

Notes

The actual cooling surface can differ because of the material, the structural shape, outside influences and the installation situation. Depending on the heat sink a heat conducting paste or heat conducting film might be necessary to keep the specified tp temperature.

3. Installation / wiring

3.1 Electrical supply/choice of LED control gear

TALEXmodule LLE from Tridonic are not protected against overvoltages, overcurrents, overloads or short-circuit currents. Safe and reliable operation can only be guaranteed in conjunction with a LED control gear which complies with the relevant standards. The use of TALEXconverter from Tridonic in combination with TALEXmodule LLE guarantees the necessary protection for safe and reliable operation.

If a LED control gear other than Tridonic TALEXconverter is used, it must provide the following protection:

- Short-circuit protection
- Overload protection
- Overtemperature protection



TALEXmodule LLE must be supplied by a constant current LED control gear.

Operation with a constant voltage LED control gear will lead to an irreversible damage of the module.

Wrong polarity can damage the TALEXmodule LLE.

If TALEXmodules LLE are wired in parallel and a wire breaks or a complete module fails then the current passing through the other module increases. This may reduce its life considerably. In addition there can be slight differences in light output caused by tolerances.

TALEXmodule LLE can be operated either from SELV LED control gears or from LED control gears with LV output voltage.



TALEXmodule LLE are basic isolated up to 300 V (if mounted with M4 screws in combination with plastic washers) against ground and can be mounted directly on earthed metal parts of the luminaire. If the max. output voltage of the led control gear (also against earth) is above 300 V, an additional isolation between LED module and heat sink is required (for example by isolated thermal pads) or by a suitable luminaire construction. At voltages > 60 V an additional protection against direct touch (test finger) to the light emitting side of the module has to be guaranteed. This is typically achieved by means of a non removable light distributor over the module.

3.2 Wiring



Wiring examples

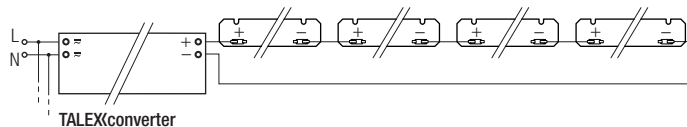

3.3 Wiring type and cross section

The wiring can be solid cable with a cross section of 0.2 to 0.75 mm². For the push-wire connection you have to strip the insulation (6–7 mm).

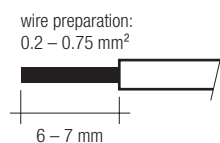

Inserting stranded wires / removing wires by lightly pressing on the push button.

3.4 Mounting instruction



None of the components of the TALEX(module LLE (substrate, LED, electronic components etc.) may be exposed to tensile or compressive stresses.

Max. torque for fixing: 0.5 Nm.

The LED modules are mounted onto a heat sink with min. 4 screws per module. In order not to damage the modules only rounded head screws and an additional plastic flat washer should be used.



Chemical substance may harm the LED module. Chemical reactions could lead to colour shift, reduced luminous flux or a total failure of the module caused by corrosion of electrical connections.

Materials which are used in LED applications (e.g. sealings, adhesives) must not produce dissolver gas. They must not be condensation curing based, acetate curing based or contain sulfur, chlorine or phthalate. Avoid corrosive atmosphere during usage and storage.

3.5 EOS/ESD safety guidelines



The device / module contains components that are sensitive to electrostatic discharge and may only be installed in the factory and on site if appropriate EOS/ESD protection measures have been taken. No special measures need be taken for devices/modules with enclosed casings (contact with the pc board not possible), just normal installation practice. Please note the requirements set out in the document EOS / ESD guidelines (Guideline_EOS_ESD.pdf) at: <http://www.tridonic.com/esd-protection>

4. Life-time

4.1 Life-time, lumen maintenance and failure rate

The light output of an LED Module decreases over the life-time, this is characterized with the L value.

L70 means that the LED module will give 70 % of its initial luminous flux. This value is always related to the number of operation hours and therefore defines the life-time of an LED module.

As the L value is a statistical value and the lumen maintenance may vary over the delivered LED modules.

The B value defines the amount of modules which are below the specific L value, e.g. L70B10 means 10 % of the LED modules are below 70 % of the initial luminous flux, respectively 90 % will be above 70 % of the initial value. In addition the percentage of failed modules (fatal failure) is characterized by the C value.

The F value is the combination of the B and C value. That means for F degradation and complete failures are considered, e.g. L70F10 means 10 % of the LED modules may fail or be below 70 % of the initial luminous flux.

4.2 Lumen maintenance for TALEX(module LLE G3 16

Forward current	tp temperature	L90 / F10	L90 / F50	L80 / F10	L80 / F50	L70 / F10	L70 / F50
250 mA	65 °C	25,000 h	32,000 h	50,000 h	63,000 h	78,000 h	98,000 h
300 mA	65 °C	24,000 h	29,000 h	47,000 h	57,000 h	72,000 h	88,000 h
350 mA	65 °C	22,000 h	26,000 h	43,000 h	50,000 h	66,000 h	78,000 h

5. Electrical values

5.1 Typ. forward voltage vs. forward current

LLE G3 16x140mm 325lm

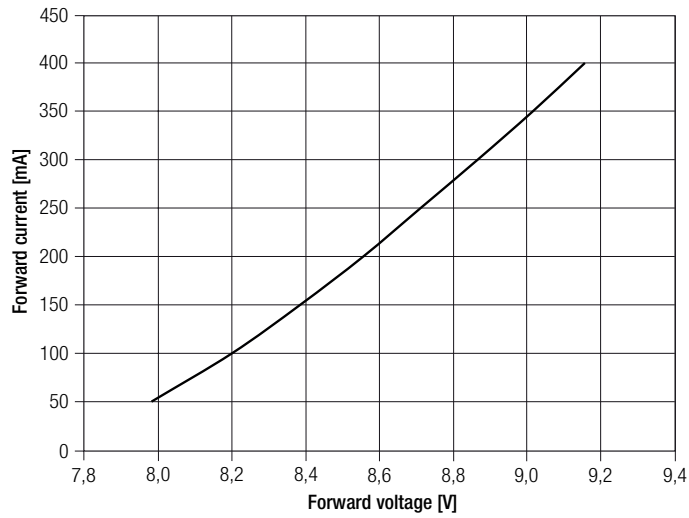

LLE G3 16x280mm 650lm

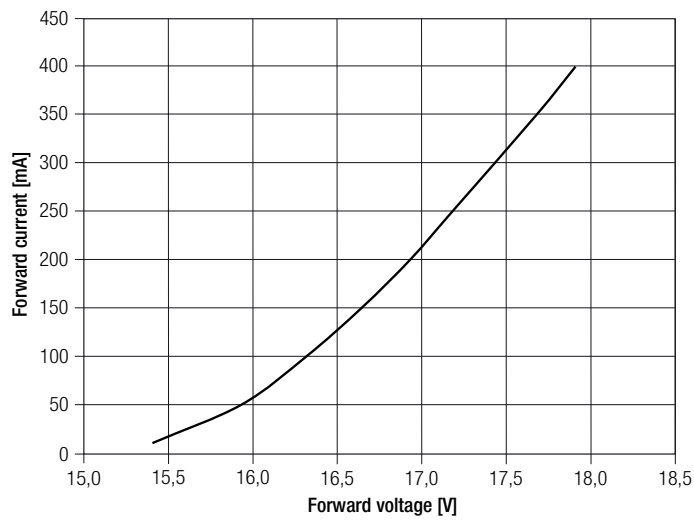

The diagrams are based on statistic values.
The real values can be different.

5.2 Forward voltage vs. tp temperature

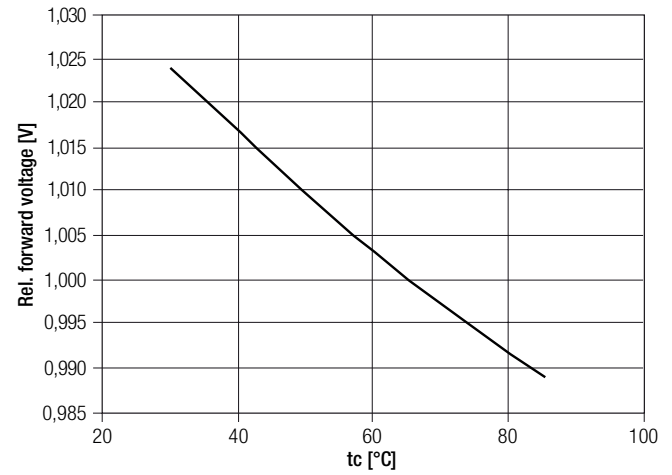

6. Photometric characteristics

6.1 Coordinates and tolerances according to CIE 1931

The specified colour coordinates are integral measured by a current impulse with typical values of module and a duration of 100 ms.

The ambient temperature of the measurement is $t_a = 25\text{ °C}$.

The measurement tolerance of the colour coordinates are ± 0.01 .

3,000 K

	x0	y0
Centre	0.4322	0.4011

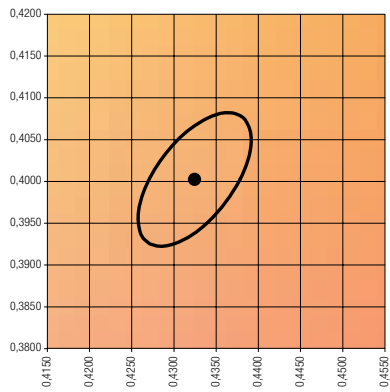

— MacAdam Ellipse: 3SDCM

4,000 K

	x0	y0
Centre	0.3771	0.3737

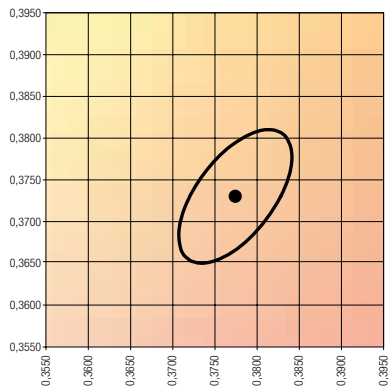

— MacAdam Ellipse: 3SDCM

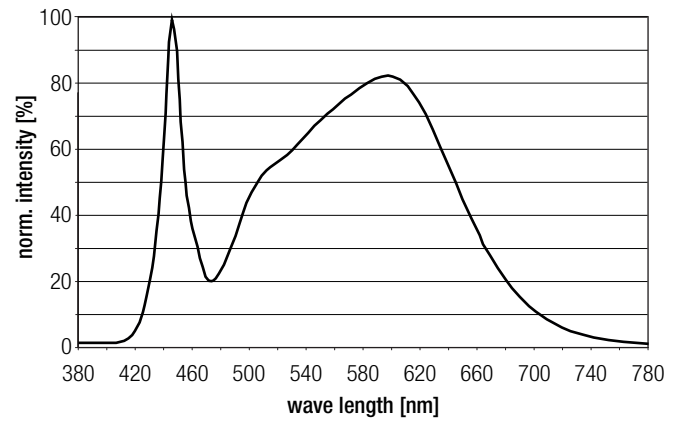
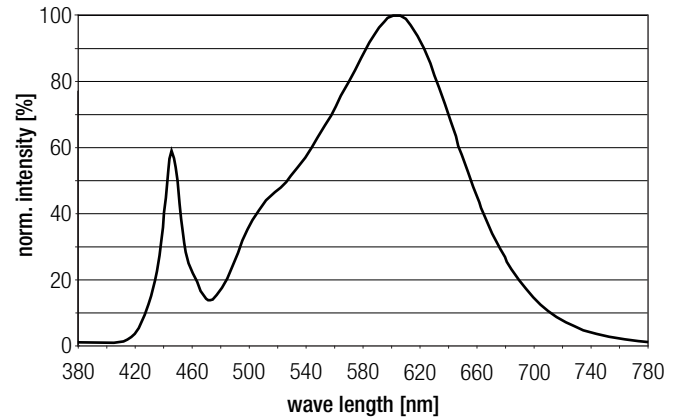

6.2 Light distribution

The optical design of the TALEX module LLE product line ensures optimum homogeneity for the light distribution.

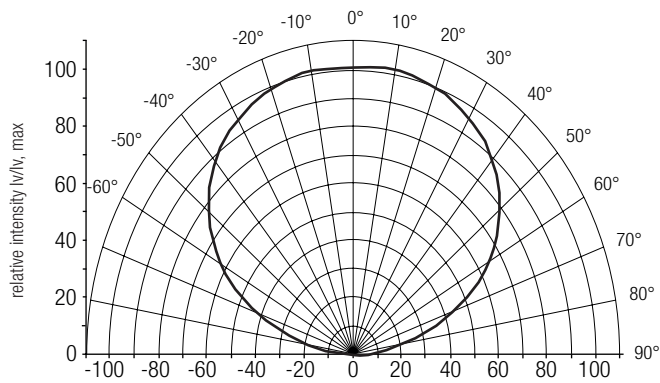

The colour temperature is measured integral over the complete module. The single LED light points can have deviations in the colour coordinates within MacAdam 7. To ensure an ideal mixture of colours and a homogenous light distribution a suitable optic (e. g. PMMA diffuser) and a sufficient spacing between module and optic (typ. 4 cm) should be used.

For further information see Design-in Guide, 3D data and photometric data on www.tridonic.com or on request.

6.3 Relative luminous flux vs. tc temperature

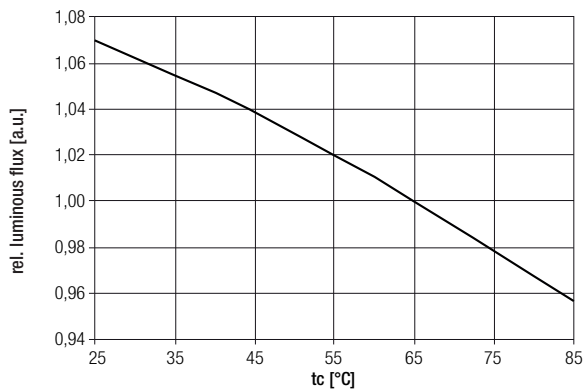

6.4 Relative luminous flux vs. operating current

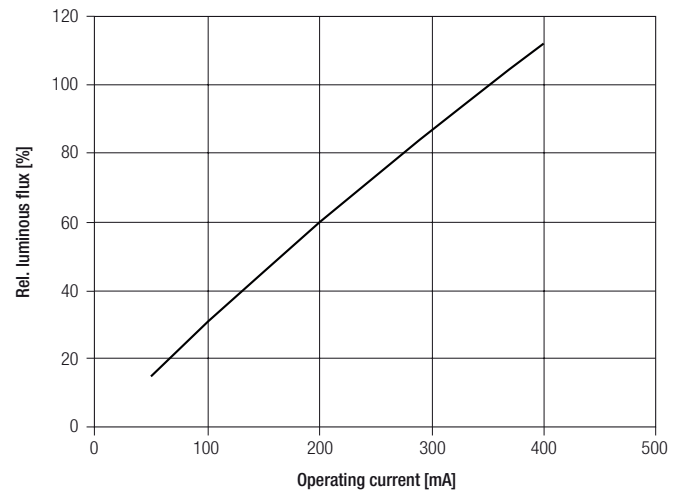

The diagrams are based on statistic values. The real values can be different.